

DIMENSIONS

RT 45L

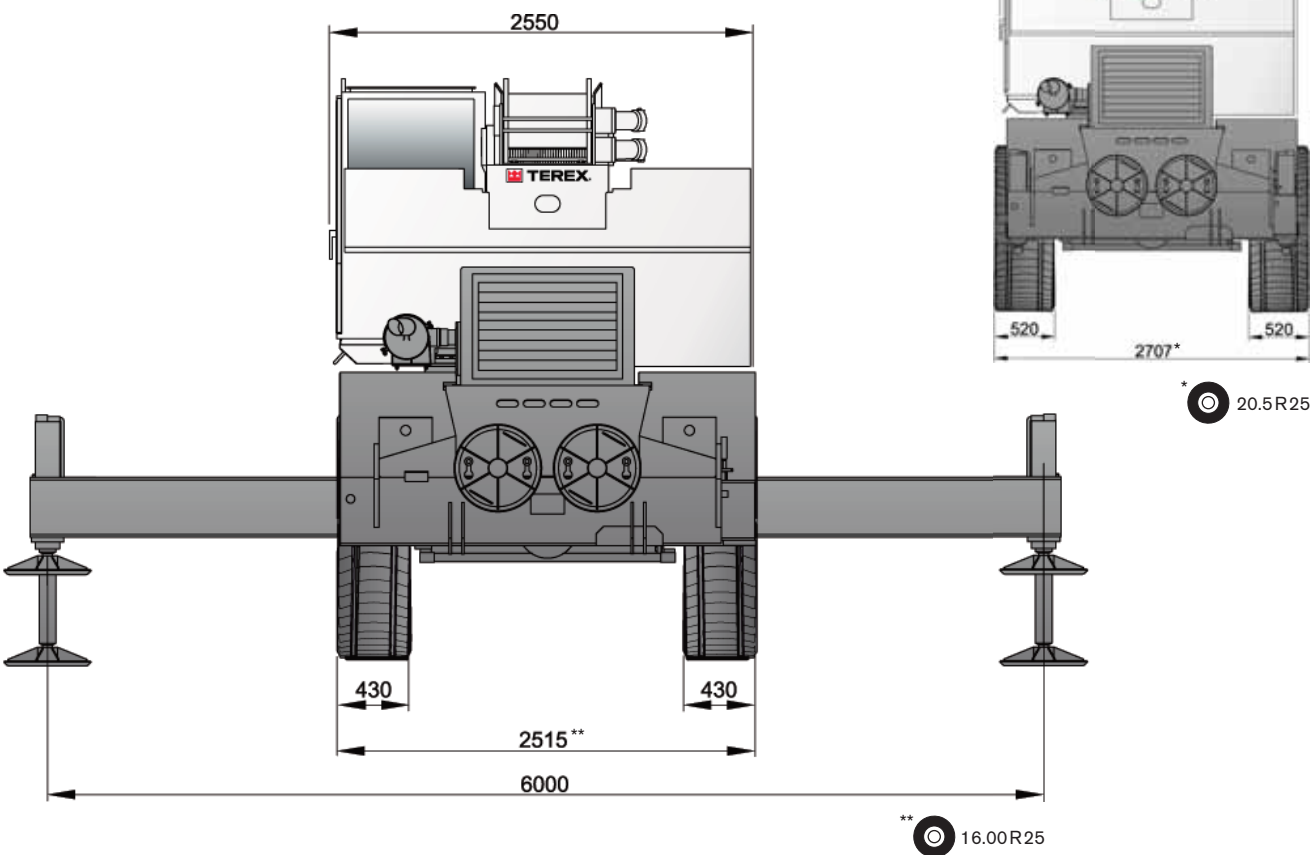

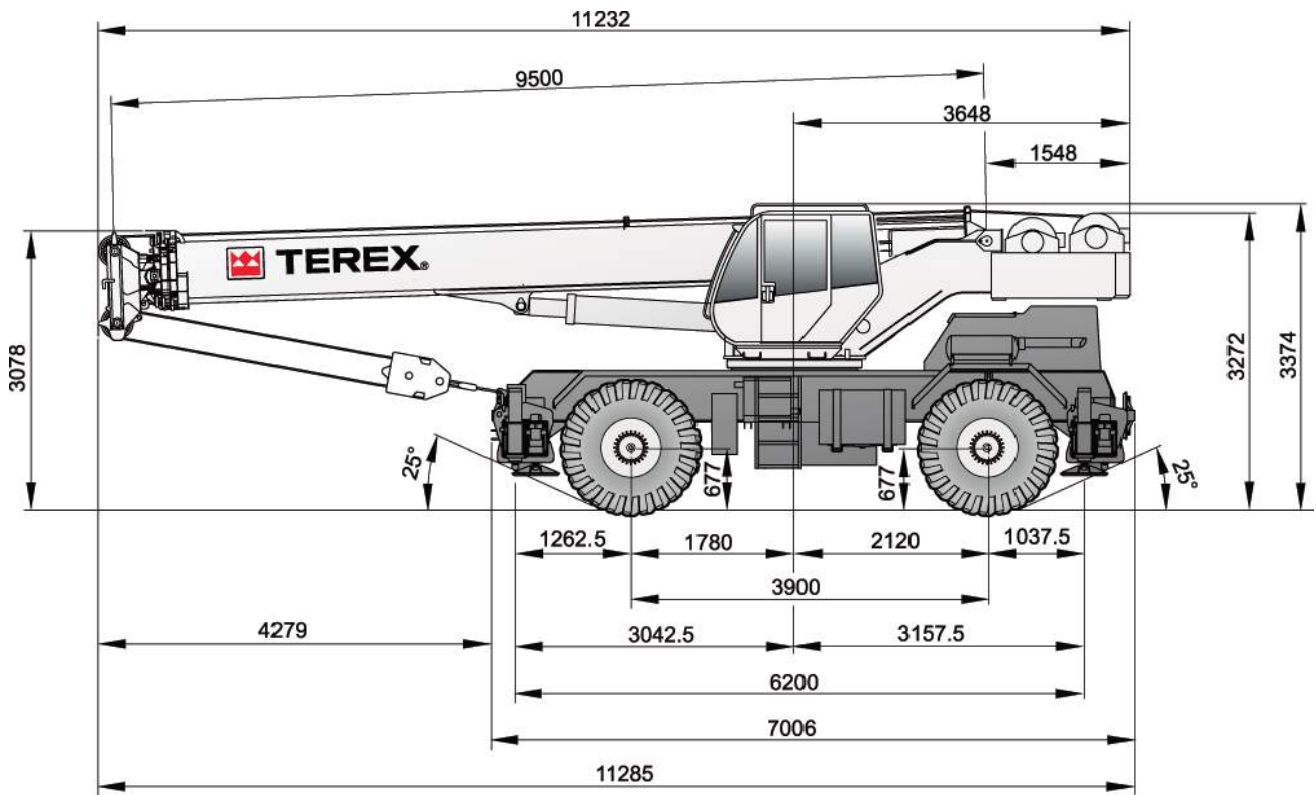





DIMENSIONS · ABMESSUNGEN · DIMENSIONI · DIMENSIONES · DIMENSÕES · ПАЗМЕРЫ

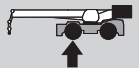
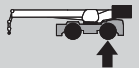
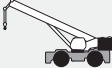

WEIGHTS

RT 45L

POIDS · GEWICHTE · PESI · PESOS · PESOS · BEC

			
 without hook block · sans crochet moufle · ohne Unterflasche · senza bozello · sin gancho · sem moitão · п/ Крюкблoк	27 200 kg	12 160 kg	15 040 kg
Add / Subtract for main optional equipment · Supplément / retrait de poids pour équipement optionnel · Für optionale Ausstattung hinzufügen / abziehen · Da sommare a seconda dell'allestimento opzionale · Sumar / restar para equipamiento opcional principal · Acrescentar / subtrair para principais equipamentos opcionais · Добавить/вычесть для дополнительного оборудования			
 8 m boxed stowed aside the boom · 8 m caissonnée, escamotable sur le côté de la flèche · 8 m Kastenprofil, seitlich am Ausleger verstaut · scatola 8 m staffata a lato braccio · 8 m tipo cajón almacenado lateralmente a la pluma · 8 m tipo caixa guardada na lateral da lança · 8 м коробчатая, укладываемая сбоку на основной стреле	+ 600 kg		
 2 **	+ 600 kg	- 70 kg	+ 670 kg
 45 t*	+ 400 kg	+ 630 kg	- 230 kg
 35 t*	+ 280 kg	+ 440 kg	- 160 kg
 25 t*	+ 260 kg	+ 410 kg	- 150 kg
 15 t*	+ 195 kg	+ 305 kg	- 110 kg
 10 t*	+ 170 kg	+ 270 kg	- 100 kg
 5 t*	+ 50 kg	+ 80 kg	- 30 kg

NOTE: Values are subject to 2% variation · REMARQUE : Les valeurs sont sujettes à une variation de 2% · HINWEIS: Werte können bis zu 2% abweichen ·
 NOTA: I valori possono variare fino al 2% · NOTA: Valores sujetos a una variación del 2% · OBSERVAÇÃO: Valores sujeitos a 2% de variação ·
 ПРИМЕЧАНИЕ. Значения даны с допуском +/- 2%

* Weight distribution calculated considering the hook block linked to the front shield of the machine · Répartition du poids calculée en considérant le crochet moufle connecté au panneau frontal de la machine · Berechnung der Gewichtsverteilung mit Hakenflasche am vorderen Rammschutz des Krans gesichert · Le distribuzioni dei pesi sono calcolate considerando il bozzello legato davanti al carro · Distribución de pesos calculada considerando el gancho asegurado al protector frontal · Distribuição de pesos calculada considerando o moitão ligado à proteção dianteira da máquina · Распределение нагрузки рассчитано для крана с крюкблoком, закрепленном на переднем щите машины

** Weight includes rope · Le poids comprend le câble · Gewicht einschließlich Seile · I pesi includono la fune · El peso incluye soporte cabrestante · Peso inclui cabo · Вес включает вес троса